

OAKLEAF
STOVES



The 2024 Collection

Welcome

A fireplace has the ability to transform any room, becoming a natural focal point. The Oakleaf Stoves Collection presents a modern range of multifuel stoves and accessories, that combines investment in design with quality materials and expert craftsmanship.

By embracing classical design themes and infusing this with contemporary design principles, we have created a variety of beautifully crafted stoves that will make a statement of enduring elegance in any room.

The Oakleaf Stoves Collection are Ecodesign Ready stoves and extremely efficient glass fronted.





CONTENTS :

- 4. Beauty & Warmth
- 6. Eco Design Ready
- 8. Langley Widescreen 5kW
- 10. Handale Widescreen 5kW
- 12. Birchley 5kW
- 14. Farrow 5kW
- 16. Cedar 5kW Widescreen
- 18. Handale 5kW
- 20. Langley 5kW
- 22. Fireside Accessories
- 27. Installation

ECO DESIGN STOVES



Lowering emissions to an absolute minimum, our collection is designed to make them some of today's cleanest burning fires.

All of our stoves have been verified as meeting the stringent air quality and efficiency standards of the Ecodesign directive, and can be found displaying the Ecodesign stoves label.





BEAUTY & WARMTH

With a stunning large portrait viewing window the Oakleaf Collection gives an amazing flame and warming glow to any room.

Modern Design



YOU WILL
FEEL RIGHT AT
HOME

Every stove in the Oakleaf Collection has been expertly designed by our specialised engineers and produced with expert craftsmanship and quality materials.

Langley Wide 5KW

Introducing the Langley Widescreen 5kW Multi-Fuel Stove, a eco design heating solution that combines cutting-edge technology with elegant design. This innovative stove is meticulously crafted to provide optimum warmth and efficiency while adding a touch of sophistication to any living space.



Langley 5kW

Widescreen

MULTI FUEL FREE STANDING STOVE

FEATURES:

- 84.9% Efficiency
- Defra Approved
- Stunning Large Glass Flame Picture
- Built In Air Wash
- 5" Top Or Rear Outlet
- Flue Draught Test Point
- British Design
- Rear Heat Shield
- Vermiculite Lined
- Integrated Handle
- Manufactured To British Quality Assurance
- Certified And Tested To European Standards (BS EN 13240)
- Ashpan And Tools

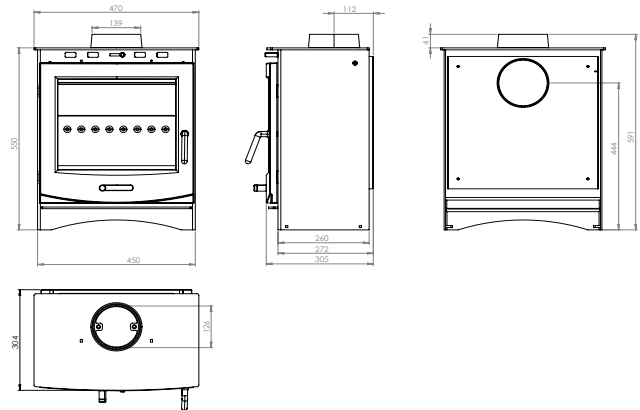

Handale Wide 5KW

Introducing the Handale Widescreen Eco Design Stove, a revolutionary heating solution that marries eco-friendly design with unmatched performance.

This stove is meticulously crafted to elevate your home's ambiance while minimizing its environmental footprint.



Handale 5kW

Widescreen

MULTI FUEL FREE STANDING STOVE

FEATURES:

- 84.9% Efficiency
- Defra Approved
- Stunning Large Glass Flame Picture
- Built In Air Wash
- 5" Top Or Rear Outlet
- Flue Draught Test Point
- British Design
- Rear Heat Shield
- Vermiculite Lined
- Integrated Handle
- Manufactured To British Quality Assurance
- Certified And Tested To European Standards (BS EN 13240)
- Ashpan And Tools

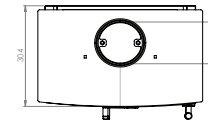
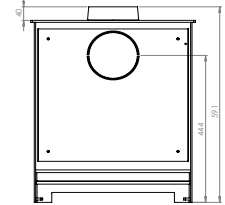
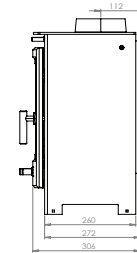
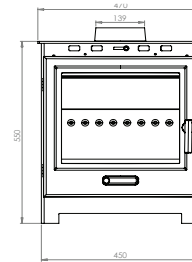

Birchley 5KW

The Birchley is an exceptional addition to any home, designed to provide both warmth and aesthetic appeal. The stove's sleek and modern design features a large glass door that provides a clear view of the flames.

In addition, the stove comes with an optional multifuel kit, allowing you to burn a range of fuels such as approved solid fuels and other smokeless fuels.



Birchley 5kW

WOOD BURNING / MULTI FUEL*
FREE STANDING STOVE

FEATURES:

- 84.4% Efficiency
- Multifuel Kit (optional*)
- Direct Air Intake
- Defra Approved
- Stunning Large Glass Flame Picture
- Built In Air Wash
- 5" Top Or Rear Outlet
- Flue Draught Test Point
- Rear Heat Shield
- Vermiculite Lined
- Intergrated Handle
- Manufactured To British Quality Assurance
- Certified And Tested To European Standards (BS EN 13240)



ECO
DESIGN
2022
READY

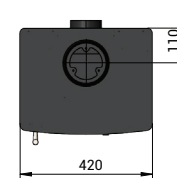
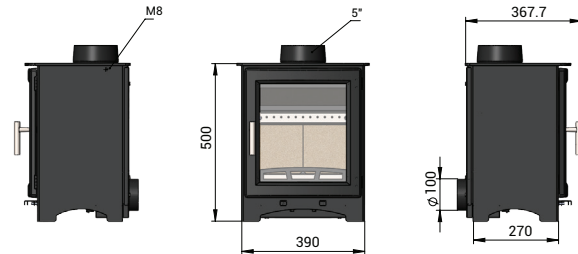

Farrow 5KW

The Farrow is an impressive addition to any home looking for a stylish and efficient heating option. This stove is designed to burn a variety of fuels, including wood, approved solid fuels, and smokeless fuels, making it a versatile choice for homeowners.

The Farrow 5kw stove boasts a sleek and contemporary design that will complement any home décor.



Farrow 5kW

MULTI FUEL FREE STANDING STOVE

FEATURES:

- Direct Air Intake
- Defra Approved
- Stunning Large Glass Flame Picture
- Built In Air Wash
- 5" Top Or Rear Outlet
- Flue Draught Test Point
- Vermiculite Lined
- Adjustable Handle
- Manufactured To British Quality Assurance
- Certified And Tested To European Standards (BS EN 13240)
- Ashpan And Tools



defra
Approved
For Smokeless Zones

ECO
DESIGN
2022
READY



UK
CA **CE**

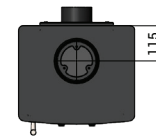
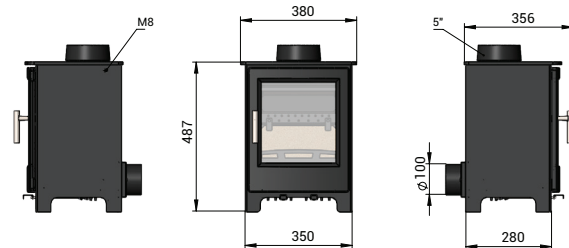

Cedar 5kW

Widescreen

The Cedar 5kW Widescreen Multifuel Stove boasts a traditional and clean design perfect to compliment any room, whilst keeping traditional and conventional settings in mind.



Cedar 5kW

MULTI FUEL FREE STANDING STOVE

FEATURES:

- 80.7% Efficiency
- Defra Approved
- Stunning Large Glass Flame Picture
- Built In Air Wash
- 5" Top Or Rear Outlet
- British Design
- Vermiculite Lined
- Adjustable Handle
- Manufactured To British Quality Assurance
- Certified And Tested To European Standards (BS EN 13240)
- Ashpan And Tools

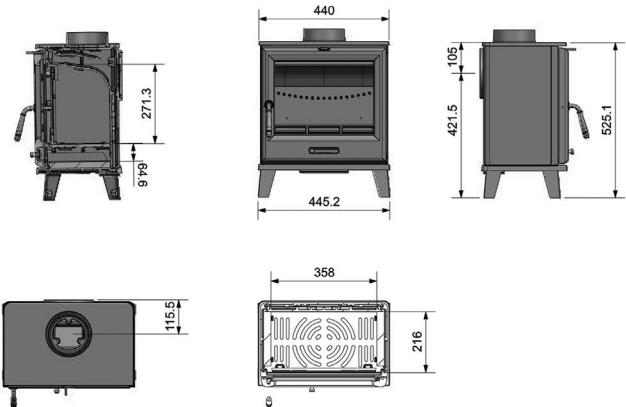

Handale 5kW

The Handale 5kW Multifuel Stove boasts a traditional and clean design perfect to compliment any room, whilst keeping traditional and conventional settings in mind.



Handale 5kW

MULTI FUEL FREE STANDING STOVE

FEATURES:

- 82.5% Efficiency
- Defra Approved
- Stunning Large Glass Flame Picture
- Built In Air Wash
- 5" Top Or Rear Outlet
- Flue Draught Test Point
- British Design
- Rear Heat Shield
- Vermiculite Lined
- Integrated Handle
- Manufactured To British Quality Assurance
- Certified And Tested To European Standards (BS EN 13240)
- Ashpan And Tools

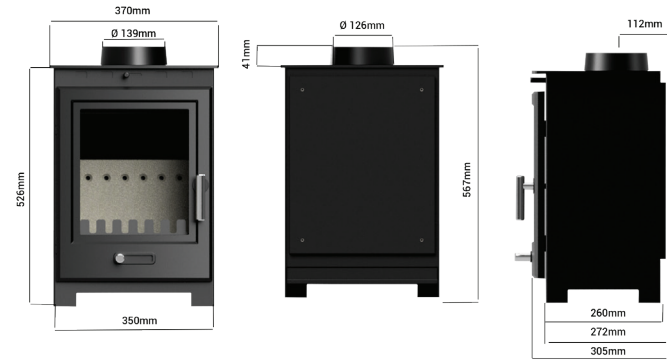

Langley 5kW

The Langley 5kW Multifuel Stove has a stylish design and large viewing window, making it a perfect match for both traditional and modern interior decor.



Langley 5kW

MULTI FUEL FREE STANDING STOVE

FEATURES:

- 82.5% Efficiency
- Defra Approved
- Stunning Large Glass Flame Picture
- Built In Air Wash
- 5" Top Or Rear Outlet
- Flue Draught Test Point
- British Design
- Rear Heat Shield
- Vermiculite Lined
- Integrated Handle
- Manufactured To British Quality Assurance
- Certified And Tested To European Standards (BS EN 13240)
- Ashpan And Tools

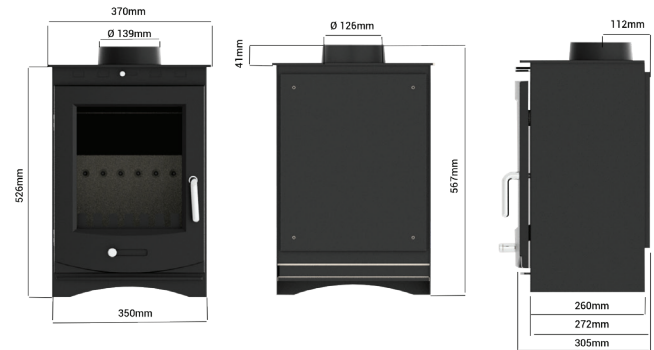

Fireside Accessories

Are you looking for fantastic fireplace accessories?

We have everything you need to make the most of your fireplace, with a wide range of fireplace accessories to compliment your home.

Our product range covers:

- Companion Sets
- Log Baskets
- Coal Buckets & Scuttles
- Log Racks & Stores
- Shovels & Brushes
- Fireside Tools
- Bellows
- Ashpans



Companion Sets

Designed to maintain and keep fireplaces and surrounds clean and tidy during use, the companion set is a necessary accessory for the home with a stove, open fire or fireplace.

Product	Code
Triangle Companion Set	ING026
26" 4 Piece Crest Companion Set	FIRE86
Matt Black Wall Hanging 4PC Fire Tool Set	FIRE214
25" Black & Pewter 5 Piece Companion Set	FIRE36
17" Black 5 Piece Companion Set	FIRE89
21" Pewter 5 Piece Fleur De Lys Companion Set	FIRE116
21" Black 5 Piece Fleur De Lys Companion Set	FIRE113
24" Black 5 Piece Cube Top Companion Set	FIRE112
25" Oval Handle 5 Piece Companion Set	FIRE28
25" Ball Top 5 Piece Companion set Black	FIRE79



Log Baskets

Designed to keep your fireside wood and kindling in one handy place, this collection of traditional log baskets features a range of designs to suit any interior setting.

Product	Code
Round Dark Wicker Basket With Chrome Handles	FIRE400
Dark Wicker Basket With Chrome Handles	FIRE200
Wicker Log Basket With Removable Lining	FIRE161
Cradle Wicker basket	FIRE162



Shovels & Brushes

Ideal for where space is limited, brush and pan sets are the perfect accessory for compact fireplaces.

Product	Code
Black Shovel & Brush Set	FIRE82
5.5" Black Shovel	FIRE80
9" Black Shovel With Wooden Handle	FIRE111
18" Black Loop Handle Shovel	FIRE136
Black Bannister Dustpan and Brush Set	FIRE212



Fireside Tools

The wonderfully classical fireplace tool has been skilfully beaten and shaped at the anvil, ready to be finished in our renowned midnight black finish.

Product	Code
Single Loop Handle Flat Scraper Black	FIRE75
Single Loop Handle Curved Scraper Black	FIRE74
18" Black Loop Handle Tongs	FIRE137
18" Black Loop Handle Poker	FIRE138
18" Black Loop Handle Traditional Poker	FIRE135
12" Black Single Scissor Tongs	FIRE130
Cast Iron Scissor Tongs Matt Black	FIRE217
18" All Black Single Loop Brush	FIRE134



Coal Buckets & Scuttles

Our coal buckets are available in a variety of finishes, an ideal alternative for those looking for a touch of modernity.

Product	Code
Premium Black Waterloo Bucket/Pewter Band	ING026
Black Coal Hod	FIRE86
Black Ellipse Hod	FIRE214
16" Black Waterloo Bucket	FIRE36
Set Of 2 Nested Black Coal Buckets	FIRE89
Premium Set Of 2 Buckets Logs, Kindling	FIRE116
Black Waterloo Bucket & Shovel Set	FIRE113
Black Metal Ash Bucket With Lid	FIRE112



Log Racks & Stores

This collection of log stores and racks offers the perfect storage solution for all of your fireside fuel.

Product	Code
Large Heavy Duty Cast Iron Log Basket	LOG07
Small Heavy Duty Cast Iron Log Basket	LOG01
Folding Log Rack With Handles	LOG03
Log Cart & Companion Set	LOG09



Fireplace Bellows

Whether you want to simply suspend them from your hearth for purely decorative purposes or to help start a crackling winter fire.

Product	Code
Dark Brown Wooden Bellows	FIRE154



Match Box Holders

Match holders, the perfect accessory for your fireside and ideal as a gift too.

Product	Code
Cream Match Holder With Long Matches	FIRE144C
Premium Metal Matches Holder	FIRE144



Ash Pan & Handle

Our ash pans are made from the finest materials to proven designs.

Product	Code
16" Silver Ash Pan	FIRE172
13" Black Ash Pan	FIRE131
Silver Ash Pan Handle	FIRE173



INSTALLATION

Your Oakleaf Collection Stove is made up of a number of different components and it is important to ensure that your installer has the necessary qualifications and experience to fit all the components of a wood burning / multifuel stove.

All Oakleaf Collection Stoves are supplied with detailed, comprehensive installation and user instructions. All installations must be in accordance with the manufacturer's instructions, current building regulations and British standards.

The installation should only be carried out by qualified competent persons. For solid fuel, a fully registered engineer.

Failure to comply with these requirements may render the appliance unsafe in the first instance, reduce the efficiency and

serviceability of your appliance and ultimately invalidate the warranty.

All installers in order to satisfy the terms and conditions of our warranty, must be registered with the appropriate regulating bodies as deemed by Oakleaf Stoves. For solid fuel installations all installers must be registered with a regulating body.

It is important that you retain all documentation following the installation as this will be required in order to activate the warranty if needed.



Get In Touch

