



FARROW 5.0kW

Ecodesign Multi-fuel Stove

USER GUIDE

PLEASE RETAIN THIS GUIDE FOR FUTURE REFERENCE

Please read this user guide carefully when you assemble, install, operate and maintain your stove.

If you have any more questions, please contact your local dealer.

READ THE INSTRUCTION BOOKLET AND THESE SUPPLEMENTARY INSTRUCTIONS CAREFULLY BEFORE INSTALLATION

These instructions together with those in the instruction booklet cover the basic principles to ensure the satisfactory installation of the stove, although detail may need slight modification to suit particular local site conditions. In all cases the installation must comply with current Building Regulations, Local Authority Byelaws and other specifications or regulations as they affect the installation of the stove.

It should be noted that the Building Regulations requirements may be met by adopting the relevant recommendations given in British Standards BS 8303, BS EN 15287-1:2007 as an alternative means to achieve an equivalent level of performance to that obtained following the guidance given in Approved Document J. Should any conflict apply between these instructions and the original manufacturer's instructions then the most stringent advice must apply.

Please note that it is a legal requirement under England and Wales Building Regulations that the installation of the stove is either carried out under Local Authority Building Control approval or is installed by a Competent Person registered with a government approved Competent Persons Scheme. HETAS Ltd operate such a Scheme and a listing of their Registered Competent Persons can be found on their website at www.hetas.co.uk.

CO Alarms: -

Building regulations require that whenever a new or replacement fixed solid fuel or wood/biomass appliance is installed in a dwelling a carbon monoxide alarm must be fitted in the same room as the appliance. Further guidance on the installation of the carbon monoxide alarm is available in BS EN 50292:2002 and from the alarm manufacturer's instructions. Provision of an alarm must not be considered a substitute for either installing the appliance correctly or ensuring regular servicing and maintenance of the appliance and chimney system.

1. INSTALLATION INSTRUCTIONS

APPLIANCE LOCATION

The appliance must be located at specific distances from its surroundings. This is to prevent damage to products & furnishings within the vicinity of the appliance. Adequate space should be provided for servicing the appliance.

We recommend furnishings be always kept 1m away, to avoid heat degradation over time. There must be a minimum clearance of 75mm each side & back of the appliance, this is to non-combustible material only, with 300mm clearance above and in front of the appliance, to provide sufficient space for heat to dissipate to room space. See below for suggested distance to combustible materials.

Distance to Combustibles	Front	Side	Back	Hearth Temp
Farrow	100cm	50cm	60cm	>100°C

VENTILATION

Your stove requires ventilation to supply it with air for combustion. Ventilation is also required to ensure the proper operation of flues and chimneys to ensure that the products of combustion are safely dispersed to the outside air. Please ensure the stove has sufficient ventilation for operation.

Extraction fans lower the pressure in a building which can cause spillage of combustion products from an open-flued appliance. This can occur even if the appliance and the fan are in different rooms. If mechanical extraction is unavoidable in the same room as your stove, then seek specialist advice to ensure safe operation of the appliance

COMPONENT SPARE PARTS

Please see below the list of spares available for your stove. Only the approved manufactures spare parts must be used. Any attempt to fabricate a replacement or to modify any parts of the stove will invalidate the warranty and may render the stove dangerous.

This could also have a detrimental effect on the environment.

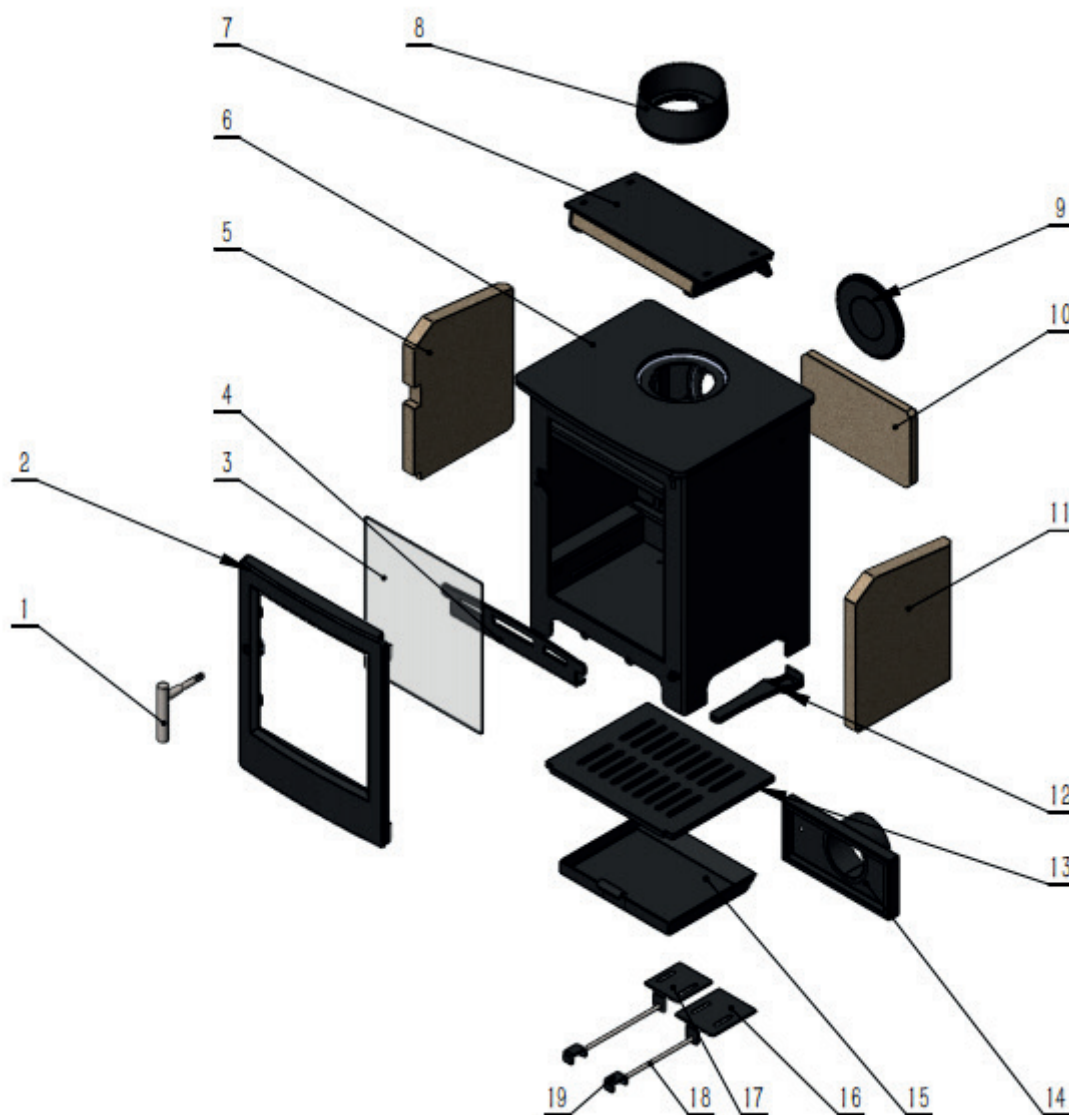

Item	Description	Item	Description
1	Handle	11	Right Brick
2	Door	12	Ashpan Handle
3	Glass	13	Grate
4	Log Retainer	14	Outer Air Box
5	Left Brick	15	Ashpan
6	Stove Body	16	Secondary Control Slide
7	Baffle Plate	17	Primary Control Slide
8	Flue Collar	18	Air Control Lever
9	Flue Blanking Plate	19	Air Control Knob
10	Rear Brick		

1. Safety Advice

1.1. Handling

Necessary facilities must be available for loading, unloading and site handling.

1.2. Metal Parts

Be careful of personal injury when installing or maintaining this appliance.

1.3. Other possible injuries

The stove contains no harmful materials, but if there is a possibility of using any dangerous materials in the course of installation then please seek specialist guidance and use appropriate protective equipment.

1.4. Important Warning

This appliance **MUST NOT** be installed into a chimney that is shared with any other heating appliance. There **MUST NOT** be an extractor fan fitted in the same room as the stove as this can cause the stove to emit fumes into the room.

1.5. Warranty

We provide a five-year warranty for the stove body. The internal accessories of the stove body are vulnerable parts and the warranty is six months. Fragile glass is not covered by the warranty.

1.6. Asbestos

This stove contains no asbestos. If there is a possibility of disturbing any asbestos in the course of installation, then please seek specialist guidance and use appropriate protective equipment.

1.7. Use of fireguard

When using the stove in situations where children, aged and/or infirm persons are present a fireguard must be used to prevent accidental contact with the stove. The fireguard should be manufactured in accordance with BS 8423:2010.

1.8. Aerosol sprays

Do not use an aerosol spray on or near the stove when it is alight.

1.9. Periods of Prolonged Non-Use

If the stove is to be left unused for a prolonged period of time, then it should be given a thorough clean to remove ash and unburned fuel residues. To enable a good flow of air through the appliance to reduce condensation and subsequent damage, leave the air controls fully open.

2. Installation

2.1. Chimney

The chimney must be fitted in accordance with manufacturer's instructions and the relevant part of the Building Regulations. The chimney height and the position of the chimney terminal should conform to Building Regulations and all local regulations, including those referring to national and European standards. The chimney must be in good condition, any cracks and obstructions are not permitted. The diameter of the flue should not be less than 125mm and not more than 200mm. If any of these requirements are not met, the chimney should be lined by a suitable method.

The chimney must be swept and examined for soundness and suitability before the appliance is installed. Remedial action should be taken if required, seeking expert advice if necessary. Where the chimney is believed to have previously served an open fire installation it is recommended that the chimney be swept a second time within a month of regular use after installation.

If you have any doubts about the suitability of your chimney, consult a local installer.

2.2. Flue Draught (Working range 12-25 Pascals)

On commissioning the Stove, a flue draught reading must be taken and documented on the commissioning certificate this reading ensures the stove is operating within its designed parameters and its optimum efficiency. Adding the flue draught reading to the commissioning report, this report will be completed by the installer. A sample point has been included on this appliance and is located on the top right-hand side of the stove. Care should be taken when proceeding with the test as all stove parts will now be hot.

Remove the screw from the test point and insert (as Shown on page 6) the hose or test probe of the manometer or draught gauge. Record the reading in pascals (Pa). The optimum reading should be in the range of 12-15Pa. A flue draught may exceed 15Pa but must not exceed 24Pa. Anything above 24Pa may result in the over-firing of the stove. As a direct consequence of this the fuel consumption will be excessive which may result in a chimney fire. Remove the hose or test probe and replace the screw confirming the test point is sealed. If the flue draught is outside the specified range for the appliance, remedial action is necessary to correct the problem and allow the chimney to operate at the correct draught. This might typically include adding a draught stabilizer to reduce too high a draught or lining and insulating an overly large chimney if the draught is too low.

The chimney must be swept before fitting a liner to the stove and it is a condition of the warranty that it must be swept every twelve months thereafter, but not limited to depending on use. If used regularly, it is recommended that your chimney is swept every six months.

2.2.2. WARNING NOTE

Properly installed, operated and maintained this stove will not emit fumes into the dwelling. Occasional fumes from de ashing and re fuelling may occur. However, persistent fume emission is potentially dangerous and must not be tolerated. If fume emission does persist, then the following immediate action should be taken:

- (a) Open doors and windows to ventilate the room and then leave the premises.
- (b) Let the fire go out.
- (c) Check for flue or chimney blockage and clean if required
- (d) Do not attempt to relight the fire until the cause of the fume emission has been identified and corrected. If necessary, seek expert advice.

The most common cause of fume emission is flueway or chimney blockage. For your own safety these must be kept clean at all times.

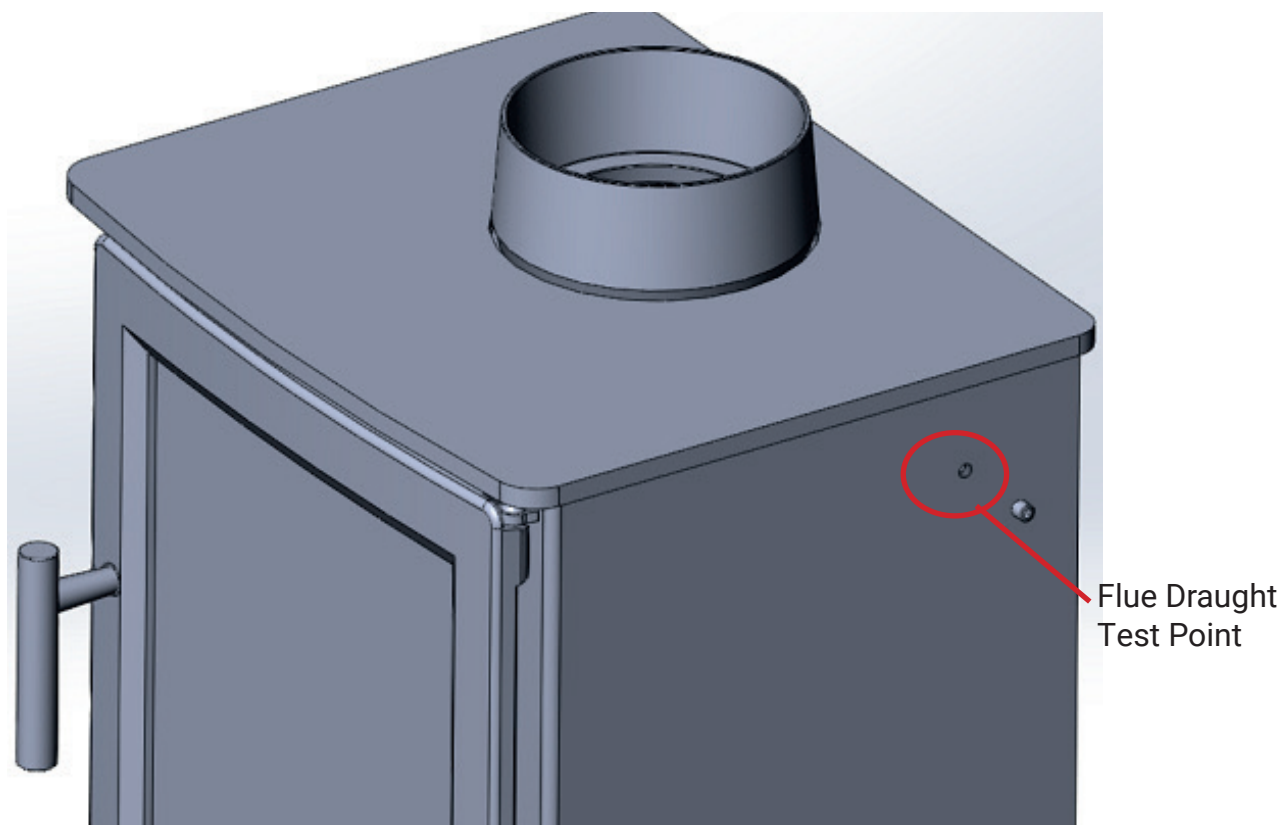

2.3. Chimney Connection

You should brick up or seal an existing fireplace opening with a register plate. A short length of flue pipe of a minimum 125mm internal diameter may then be used to connect the stove to the chimney. This flue pipe should conform to Building Regulations. Ensure that the pipe end is no closer than 76mm to the side or rear chimney walls.

Ideally, the old fireplace should be filled in so that there is a smooth streamlined entry into the flue way. The length of any horizontal run of flue pipe must not exceed 125mm.

It is essential that all connections between the stove and chimney-flue are sealed and made airtight. This appliance is not suitable for installation in a shared flue system.

Both the chimney and flue pipe must be accessible for cleaning and if any parts of the chimney cannot be reached through the stove (with baffle removed), a soot door must be fitted in a suitable position to enable this to be done.

2.4. Air Supply

A permanent, unobstructed air opening is essential for the room or space containing this appliance. The air opening should be at least 3625mm² when a draught stabilizer is equipped. Due care for air requirements will need to be taken if any other appliances are permitted to work in the same room and space.

2.5. Air Inlet

Your stove requires air to function, this enters at the bottom rear of the appliance. A direct supply air kit is included as standard as a connection point for direct supply/duct installation requirements.

2.6. Material Clearances

It is workable for the appliance to be recessed in a prepared fireplace, but a suitable free air gap must be left around the sides, top and back of the appliance to reach maximum heat output and for access to the rear of the stove.

In all instances the back wall of the fireplace recess and the hearth should be made of non-combustible material.

The hearth on which the stove is to be placed should not be less than 25-30mm thick and should be in accordance with the current building regulations.

Care should be taken to level the stove using the adjusting screws in the feet.

The appliance shall be installed on a floor with adequate load-bearing capacity. If the existing construction does not meet this prerequisite, suitable measures (e.g. load disturbing plate) should be taken to achieve it.

2.7. Commissioning and Handover

You should leave an appropriate period of time for fire cement and mortar to dry out upon completion of the installation. In order to ensure the smoke and fumes are taken from the stove up the chimney and emitted safely to atmosphere, a small fire should be lit first. Do not run the stove at full output for at least 24 hours.

Finishing the installation and commissioning, the operating instructions and tools for your stoves should be kept in hand. It is also important to know how to use the stove properly and use only the recommend fuels for this appliance. The user should know how to have smoke or fumes emitted properly from the stove and be warned to prevent injuries in case of the presence of children, aged or infirm persons.

3. Operating Instructions

Operation with the door open can cause excess smoke. The appliance must not be operated with the appliance door left open except as directed in this user guide.

Operation with the air controls or appliance dampers open can cause excess smoke. The appliance must not be operated with air controls, appliance dampers or door left open except as directed in this user guide.

3.1. Important Information

All local regulations, including those referring to national and European Standards need to be complied with when installing the appliance.

This appliance is not suitable for installation in a shared flue system.

The firebox and ash pit cover shall be kept closed except during ignition, refuelling and removal of residue material to prevent fume spillage. It is important to use this appliance correctly to achieve best results.

3.1.1 The Clean Air Act 1993 and Smoke Control Areas

The Clean Air Act 1993 and Smoke Control Areas Under the Clean Air Act local authorities may declare the whole or part of the district of the authority to be a smoke control area. It is an offence to emit smoke from a chimney of a building, from a furnace or from any fixed boiler if located in a designated smoke control area It is also an offence to acquire an unauthorized fuel” for use within a smoke control area unless it is used in an “exempt” appliance (“exempted “from the controls which generally apply in the smoke control area).

In England appliances are exempted by publication on a list by the Secretary of State in accordance with changes made to sections 20 and 21 of the Clean Air Act 1993 by section 15 of the Deregulation Act 2015 Similarly in Scotland appliances are exempted by publication on a list by Scottish Ministers under section 50 of the Regulatory Reform (Scotland) Act 2014.

In Wales and Northern Ireland these are authorized by regulations made by Welsh Ministers and by the Department of the Environment respectively.

Further information on the requirements of the Clean Air Act can be found here at: <https://www.gov.uk/smoke-control-area-rules> Your local authority is responsible for implementing the Clean Air Act 1993 including designation and supervision of smoke control areas and you can contact them for details of Clean Air Act requirements.

The Farrow 5.0kW Multi-fuel stove have been recommended as suitable for use in smoke control areas when burning wood logs. The Farrow 5.0kW Multi-fuel stove must be fitted with a permanent stop to prevent closure of the combustion air controller beyond 6mm open.

3.2. Air Controls

Warning! Parts of the appliance, especially the external surfaces will be hot when in operation and due care need to be taken e.g. Protective gloves should be given in operation.

It is essential for the appliance to have sufficient air supply for combustion and ventilation.

If the stove is to be installed in a designated Smoke Control Area (further information can be found via <https://www.gov.uk/smoke-control-area-rules>) then the secondary air lever must be fitted with a restrictor plate to prevent total closure of the secondary air control. The restrictor is the bottom secondary intake as shown.

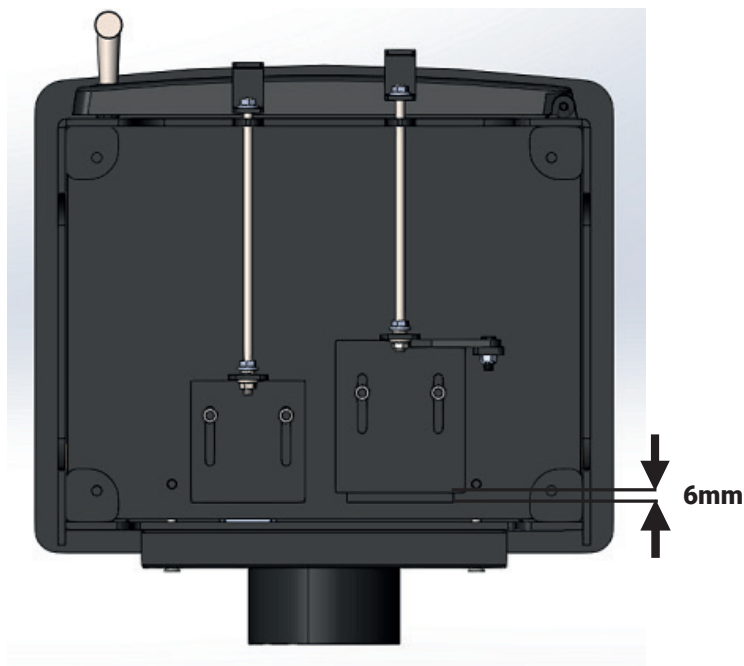

Restrictor Open

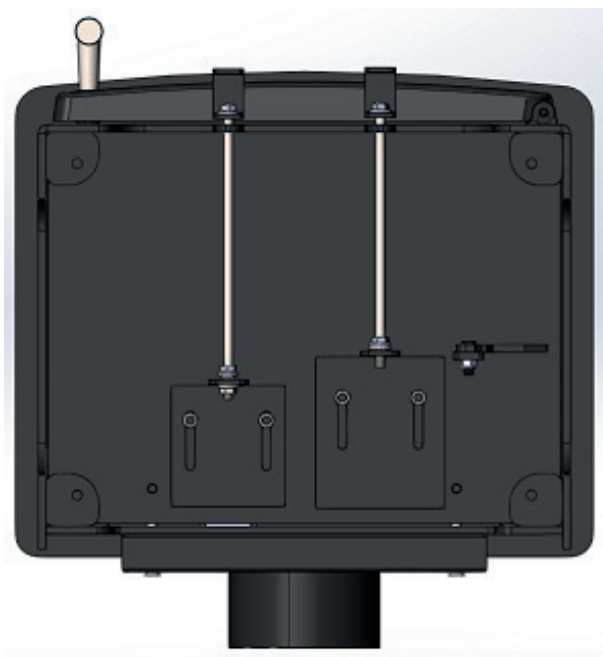

Restrictor Closed

3.2.1. Primary Air

Primary air is controlled through the assembly on the bottom of the door. This provides a conventional air draught which passes through the fuel bed. The primary air intakes can be adjusted to control the fire in combustion chamber.

3.2.2. Secondary Air

The appliance is fitted with an air wash system which can keep the heat-resistant glass of the fire door clean. This secondary air is controlled through the fittings on the bottom of the stove.



3.3. Grate

There are Two options: Rotary style and grid style. For rotary style grate, you can operate it by dragging a stainless-steel rod forward and backward to de-ash. For grid style grate, a special hook is supplied to de-ash. It is highly recommended to de-ash regularly in case any build-up of ash will damage the cast iron fuel bed. You should be careful of any hot parts.

Ash Pan

It is essential that you clean up the ash pan regularly. Use the supplied tool to lift the ash pan out of the stove.

3.4. Burning Wood

The refuelling intervals at nominal heat output will be approximately 1.5 hours. You may load wood higher in the stove than solid mineral fuel, but wood or logs are not permitted to touch the baffle plate.

Wood burns most efficiently with the primary air controls closed and the secondary control partially open. Moving the secondary control will control the burn rate of the stove.

Wood burns best with a layer of ash on the fuel bed, and care should be taken to only remove surplus residue from the stove timely.

We recommend you only use dry, seasoned wood as fuels; the wood should have been cut, split and stacked for at least one year in a circulating air surround to dry out. Otherwise, wet or unseasoned wood will cause tar deposits in the stove and unsatisfactory heat output will occur.

We recommend the use of wood logs with a moisture content of less than 20%.

Burning wet or unseasoned wood will create excess smoke emissions, tar deposits in the stove and chimney and will not produce a satisfactory heat output. Wood fuel purchased from an approved source may still require some drying out to remove surface water before use.

3.5. Refuelling on to a low fire bed

If there is insufficient burning material in the fire bed to light a new fuel charge, excessive smoke emission can occur. Refuelling must be carried out onto a sufficient quantity of glowing embers and ash that the new fuel charge will ignite in a reasonable period. If there are too few embers in the fire bed, add suitable kindling to prevent excessive smoke.

3.6. Fuel overloading

The maximum amount of fuel specified in this user guide should not be exceeded, overloading can cause excess smoke. We suggest that you refuel every 45 minutes to 1 hour, dependent on fuel.

The recommended maximum dimensions of wood logs are as specified below:

Model	Max Fuel Load	Max Log Length
Farrow	1.02kg	280mm

4. Lighting the stove

1. Open the door and ensure the secondary/ air-wash control lever is opened fully. It's the control on the right.
2. On first lighting, we recommend using 2 - 3 firelighters along with wood kindling built in a pyramid above the firelighters to obtain a good fire bed. Ignite the firelighters then close the stove door and allow the firelighters and wood kindling to ignite to the point where the embers are glowing.
3. Add your fuel of choice and control the stove as advised. Burn small loads initially in your new appliance before full fires are used, to allow paint & fitting cement to cure.

Controlling Stove

4.1.1 Burning wood

- Air-wash/secondary air lever (The control to the right) - Use this to control the fire when burning wood.
- Primary air control lever (The control to the left) – This should be closed as wood does not need air from below to burn effectively.
- Avoid overloading your appliance as this may cause damage to the product and cause unstable burn conditions. See max fuel load stated in 'Refuelling Wood' section for more info.

4.1.2 Burning smokeless fuel

- The Air-wash/secondary air lever (The control to the right) – This should be left partially open, to allow the air-wash system to keep the glass clean.
- Primary air control lever (The control to the left) - When burning coal, the stove should be mainly controlled using this lever.
- Avoid prolonged periods of slow burning which may cause build-up of creosote with certain fuels. Using a flue temperature gauge can help achieve the optimum temperature for clean combustion. See bottom of page 17 for optimum flue temperature for the relevant fuels.

4.1. Recommended Fuels

- Split and dried logs properly seasoned with less than 20% moisture content (max fuel load on page 10 should not be exceeded).
- Eco Logs.

5. Maintenance

5.1. Stove body

Use a soft brush to clean the stove; cleaning must **ALWAYS** be done after it has cooled down. The finish can be renewed with proprietary stove paint.

5.2. Baffle plate

Remove and clean the baffle plate once a month to avoid soot or fly ash. Block the flue ways and produce dangerous fume emission.

5.3. Fireproof glass

Use a proprietary glass cleaner to clean the glass when cool. Any material that may damage the glass should not be used to clean the panel. Wet logs on heated glass, a badly aimed poker or heavy slamming of the doors could crack the glass panels and care should be taken.

5.4. Ceramic rope

Ceramic or fiberglass rope is used on the stoves. Inspect the rope around the door and glass. If rope is becoming detached, use a proprietary rope glue to reattach it. Ensure you replace the rope in the case of it being in poor condition.

5.5. Flue & Chimney

Keep the chimney, flue way and any connection flue pipe swept regularly.

For users of smokeless fuels, sweep at least once a year; for wood and other fuels, at least twice a year. If the stove is fitted in place of an open fire, then the chimney should be swept one month after installation to clear any soot falls which may have occurred due to the difference in combustion between the stove and an open fire.

6. Troubleshooting

Problem	Probable Cause	Recommended Action
Fire Difficult to Light	Green/Wet Wood	Use Recommended Fuel
	Insufficient Air	Open Air Controls
	Insufficient Draft	Check flue is not obstructed, sweep if needed
	Fuel Too Large	Use kindling/small logs to start fire
Fire Burns Too Quickly	Too Much Air	Reduce Air Controls
	Excessive Draft	Install Draft Stabilizer/Damper
	Insufficient Seal	Check condition of rope seal around glass
Smokes Upon Initial Lighting	Cold Flue Pipe	Burn firelighters/small fuel loads to preheat flue prior to using larger fuel
Smokes While Burning	Insufficient draft	Check flue is not obstructed
Glass Blackening	Insufficient Air	Open air-wash control
	Damp Fuel	Use Recommended Fuel
	Insufficient Seal	Check condition of rope seal around glass
Glass Crazing (Minute Splinter Marks On Glass)	Cold liquid hitting warm glass	Replace Glass
Low Heat Output	Poor Quality Fuel	Use recommended fuels
	Insufficient Seal	Check condition of rope seal around glass

7. Technical information

Appliance	Farrow	
Fuel Type	Beech	Smokeless Fuel
Output kW (nominal)	5.0	4.9
Efficiency (%)	75.6	86.5
Seasonal Efficiency (%)	65.6	76.5
CO Emissions at 13% O2 (vol%)	0.12	0.10
NOx Emissions at 13% O2 (mg/m03)	102	111.0
CxHy (OGC) Emissions at 13% O2 (mg/m03)	118	45
Dust (PM) Emissions at 13% O2(mg/m03)	28	16
Flue gas temp. (oC)	282	210

8. Dimensions

Appliance	Height (mm)	Width (mm)	Depth(mm)	Weight (kg)	Collar (mm)	Maximum Log Length (mm)
Farrow	531	380	377	64	5" /130	250 x100

9. Technical Drawings

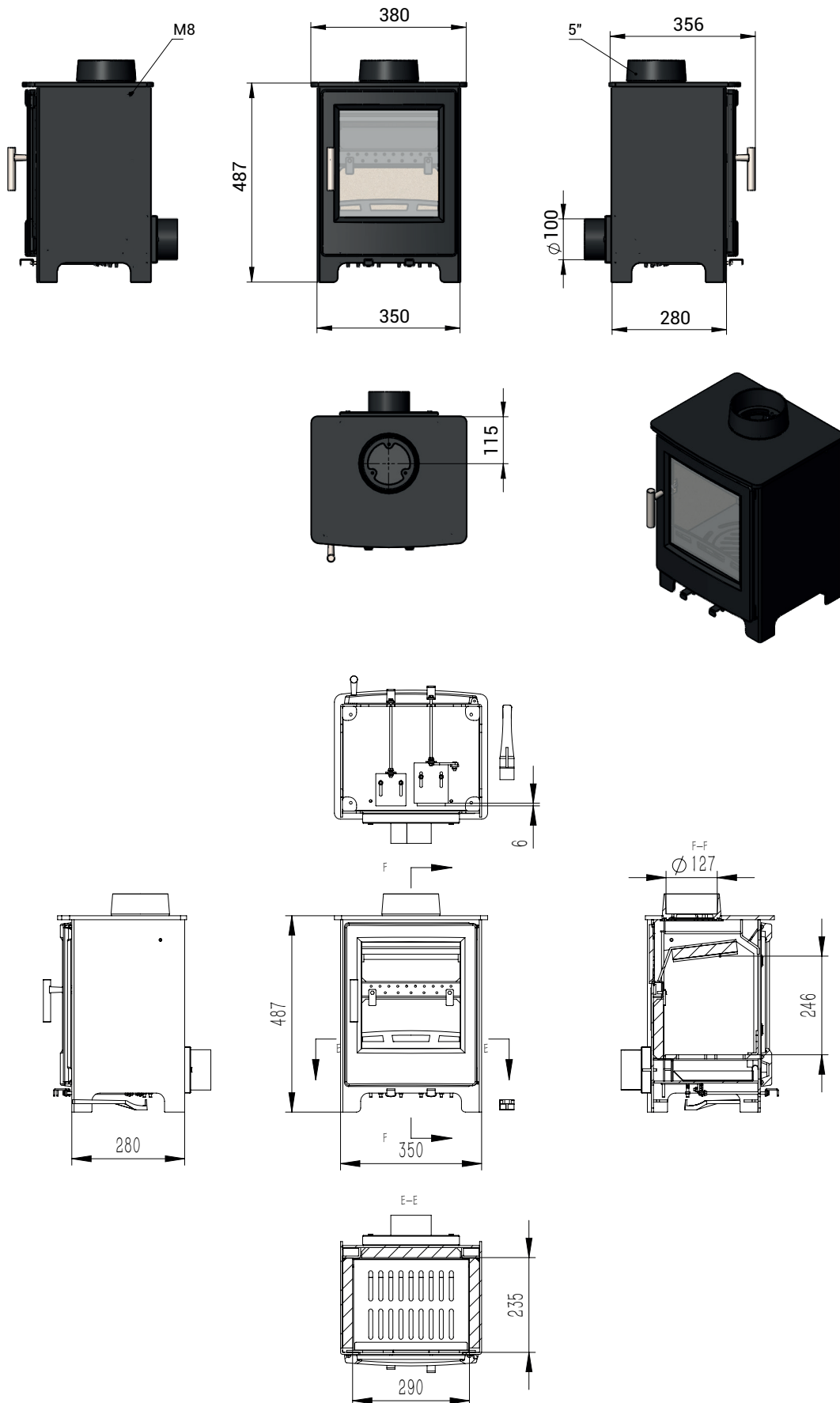

Product Fiche	
	
Commission Delegated Regulation (EU) 2015/1186 Energy Labelling of Local Space Heaters	
Manufacturer Name:	Flue Supplies
Model Name:	Farrow
Energy Efficiency Class:	A
Energy Index	100.0
Nominal Heat Output to Room	5.0
Net Efficiency:	75.6
Comments/Installation/Handover Instruction:	



ENERG
енергия · ενεργεια

Y IJA
IE IA



OAKLEAF STOVES

Farrow

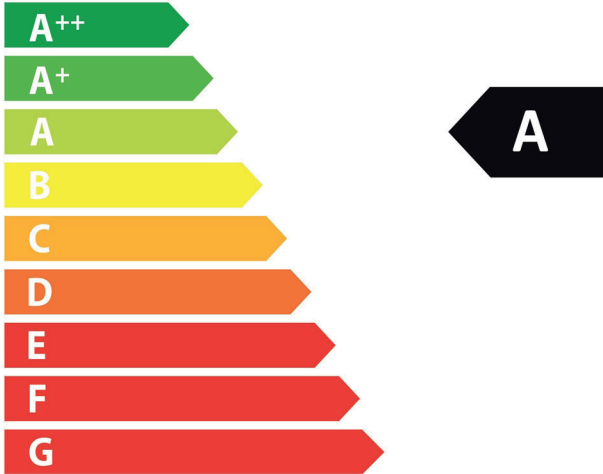

A++
A+
A
B
C
D
E
F
G

A

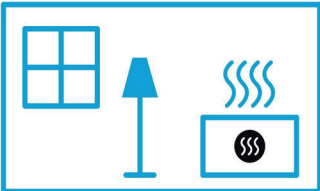

5,0
kW

ENERGIA · ЕНЕРГИЯ · ΕΝΕΡΓΕΙΑ · ENERGIJA · ENERGY · ENERGIE · ENERGI

2015/1186

10. Disposal After Product Life Expired

To Dispose of the stove after the product life has expired, please observe the following information:

- Dispose of the items correctly i.e., separate the parts to be disposed of in material groups
- Always dispose of the items in a way that is as sustainable as possible and that is in line with the current environmental protection, reprocessing/recycling and disposal technology